

CONCERTONE™
OPERATING INSTRUCTIONS
COMPACT DISC SATELLITE
STEREO RADIO SYSTEM

WARRANTY

ONE (1) YEAR LIMITED WARRANTY

CONCERTONE warrants to the original retail purchaser of this radio that it or any part therein, under normal use and conditions, be proven defective in material or workmanship within 1 year from the date of original purchase, such defect/s will be repaired or replaced at **CONCERTONE'S** option without charge for parts and repair labor.

This warranty does not extend to the elimination of externally generated static or noise, to the correction of antenna generated noise or to the cost incurred to correct this noise. The warranty does not cover the removal/reinstallation of this radio or damage to any tapes, CD's, speakers, accessories, or the vehicle's electrical system.

This warranty does not cover the cabinet appearance or apply to the radio or any part of the radio which in the opinion of **CONCERTONE**, has been damaged through alterations, improper installation, mishandling, misuse, neglect, or accident. **THE EXTENT OF CONCERTONE'S LIABILITY UNDER THIS WARRANTY IS LIMITED TO THE REPAIR OR REPLACEMENT PROVIDED ABOVE, AND IN NO EVENT, SHALL CONCERTONE'S LIABILITY EXCEED THE PURCHASE PRICE PAID BY THE ORIGINAL BUYER FOR THE RADIO.**

This warranty extends only to the original purchaser of the radio and is not transferable.

Some states do not allow limitations on how long an implied warranty last, and some states do not allow the exclusion or limitation of incidental or consequential damages, so the above limitations or exclusion may not apply to you. This warranty gives you specific legal rights.

To obtain repair or replacement within the terms of this warranty, the radio is to be delivered with proof of purchase with a description of the defect/s, freight prepaid, to the original dealer



The lightning flash and arrowhead within the triangle is a warning sign alerting you of "dangerous voltage" inside the product.

WARNING

**RISK OF ELECTRIC SHOCK
DO NOT OPEN**

WARNING: TO REDUCE THE RISK OF ELECTRIC SHOCK, DO NOT REMOVE COVER (OR BACK) NO USER-SERVICEABLE PARTS INSIDE. REFER SERVICING TO QUALIFIED SERVICE PERSONNEL.



The exclamation point within the triangle is a warning sign alerting you of important instructions accompanying the product.

CAUTION: INVISIBLE LASER RADIATION WHEN OPEN AND INTERLOCKS DEFEATED. AVOID EXPOSURE TO BEAM.

ADVARSEL: USYNLIG LASERSTRÅLING VED ÅBNING NÅR SIKKERHEDSAFBRYDERE ER UDE FUNKTION UNDGA UDSÆTTELSE FOR STRÅLING.

VARO: AVATTAESSA JA SUOJALUKITUS OHITETAESSA OLET ALLTINA NÄKYMÄTTÖMÄLLE LASER-SÄTEILYLLE. ÄLÄ KATSO SÄTEESEEN!

WARNING: OSYNLIG LASERSTRÅLNING NÅR DENNA DEL ÄR ÖPPNAD OCH SPÄRREN ÄR URKOPPLAD BETRAKTA EJ STRÅLEN!

- THIS DEVICE COMPLIES WITH PART 15 OF THE FCC RULES. OPERATION IS SUBJECT TO THE FOLLOWING TWO CONDITIONS: (1) THIS DEVICE MAY NOT CAUSE HARMFUL INTERFERENCE, AND (2) THIS DEVICE MUST ACCEPT ANY INTERFERENCE RECEIVED, INCLUDING INTERFERENCE THAT MAY CAUSE UNDESIRED OPERATION.

- COMPLIES WITH DHHS RULES 21CFR SUB-CHAPTER J APPLICABLE AT DATE OF MANUFACTURE.

WARNING: TO REDUCE THE RISK OF FIRE OR ELECTRIC SHOCK, DO NOT EXPOSE THIS APPLIANCE TO RAIN OR MOISTURE.

This product contains a low power laser device. To ensure continued safety, do not remove any covers or attempt to gain access to the inside of the product. Refer any servicing to qualified personnel.



NAMES OF CONTROLS

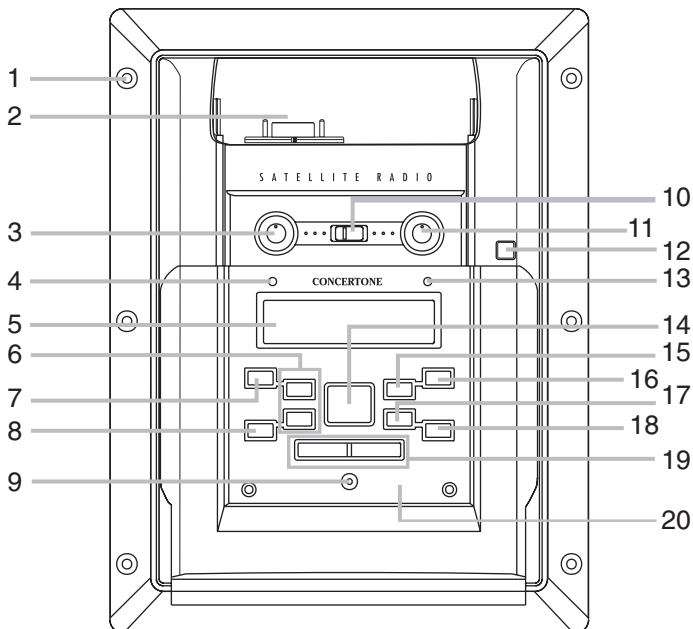

- | | |
|-------------------------------------|--|
| 1. Mounting hole | 12. CD DOOR OPEN/CLOSE button |
| 2. Satellite cradle | 13. X-BASS indicator |
| 3. BASS control knob | 14. ► PLAY/PAUSE button |
| 4. POWER ON indicator | 15. ☑ MEMORY • CLOCK control |
| 5. LCD display | 16. FUNCTION (CD/TUNER/SAT/AUX) button |
| 6. ◀◀ TUNING/SKIP ▶▶ button | 17. SLEEP/TIMER button |
| 7. POWER ON/OFF button | 18. SNOOZE button |
| 8. STOP/BAND button | 19. VOLUME controls |
| 9. REMOTE SENSOR | 20. CD door |
| 10. A/A+B/B SPEAKER selector switch | |
| 11. TREBLE control knob | |

NAMES OF CONTROLS - REMOTE CONTROL

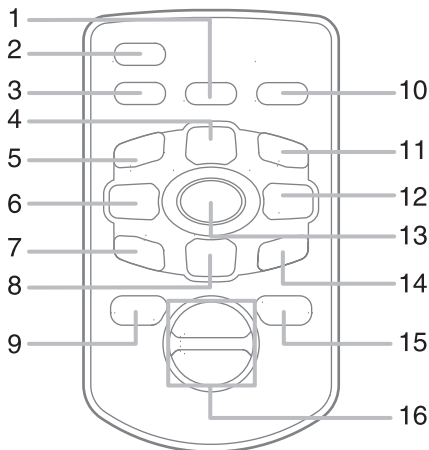

1. DISPLAY button
2. POWER button
3. FUNCTION (CD/TUNER/SAT/AUX) button
4. PRESET/REPEAT button
5. ■ STOP/BAND button
6. ▼ TUNING/◀◀ SKIP buttons
7. MEMORY ⌚ button
8. RANDOM button
9. SLEEP button
10. SNOOZE button
11. PLAY/PAUSE button
12. ▲ TUNING/▶▶ SKIP buttons
13. X-BASS button
14. INTRO button
15. TIMER button
16. VOLUME +/- button

USING THE REMOTE CONTROL CORRECTLY

- Point the Remote Control at the REMOTE SENSOR located on the unit.
- When there is a strong ambient light source, the performance of the infrared REMOTE SENSOR may be degraded, causing unreliable operation.
- The recommended effective distance for remote operation is about 6 meters (19 feet).

TO CHANGE REMOTE BATTERY

1. Open the battery door.

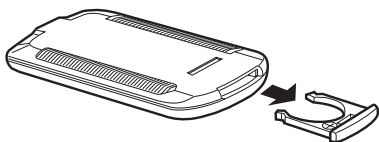

2. Insert one CR2025 (3V) size battery and replace the battery door.

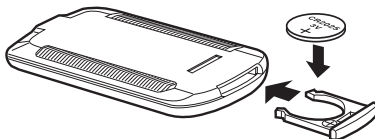

BATTERY REPLACEMENT

When battery becomes weak, the operating distance of the Remote Control is greatly reduced and you will need to replace the battery.

NOTE: If the Remote Control is not to be used for a long time, remove the battery to avoid damage caused by battery leakage corrosion.

ATTENTION

Before operating remote control for the first time. Take out the PVC sheet before operating the Remote Control.



TURNING ON THE UNIT

TO TURN ON THE UNIT

Press the POWER ON/OFF button, the POWER ON indicator will light up. Select the desired function and the corresponding function indicator will light up.

TO TURN OFF THE UNIT

Press the POWER ON/OFF button to STANDBY, the POWER ON indicator will turn off and the clock display will be shown.

CLOCK SETTING

1. In standby mode, press and hold the  MEM button for about 3 seconds until time format blinks on display.



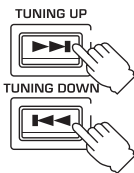

2. Press the  TUNING/ SKIP  buttons to set 12 Hour or 24 Hour time format.



3. Press the MEM button, the Hour blinks.



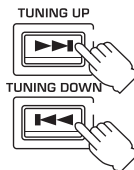

4. Press the  TUNING/ SKIP  buttons to set correct hour.



5. Press the  MEM button, the Minute blinks.



6. Press the  TUNING/ SKIP  buttons to set correct minute, and then press the MEM button to start the clock.

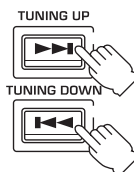

Note: Your unit is factory preset in 12 hour display. However, if there is a power failure or the unit has not been connected to power for a long period

of time, the display may shift to 24 hour.

ADJUSTING THE SOUND

TO ADJUST VOLUME

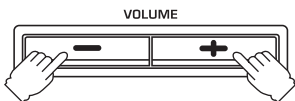

TO SELECT X-BASS (for remote only)

X-BASS is designed specifically to boost the low frequency sound to obtain a more powerful bass.

Note: Press the X-BASS button, the indicator of X-BASS will light up.





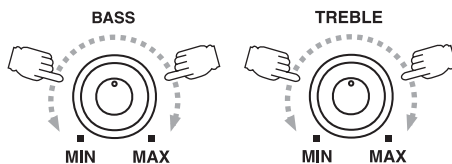

TO ADJUST BASS AND TREBLE

Turn the slide knobs to adjust the bass and treble output.



TIMER OPERATION

The power can be turned on automatically at a preset time so that you can wake up and listen to the CD or RADIO. Make sure the clock is correct before **TIMER PLAY**. Please refer to **CLOCK** setting procedure.

1. Press and hold **TIMER** button for about 3 seconds until "TIMER" indicator blinks on display.
 
2. While "TIMER" indicator blinks on display, press and hold the **MEM** button for about 3 seconds until hour blinks on display.
 
3. Press the **◀◀ TUNING/SKIP ▶▶** buttons to set hour.
 

4. Press the **MEM** button. The minute will blink.
5. Press the **◀◀TUNING/SKIP ▶▶** buttons to set minutes and press the **MEM** button to "confirm". Finally the "TIMER" indicator will stop blinking after 3 seconds on display.

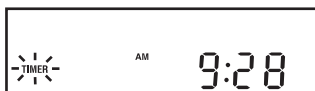
6. Press the **FUNCTION** button to select the desired program source:
 - TUNER:** Select a **BAND** and station.
 - CD:** Insert a disc.
 - SAT:** To connect Satellite Radio
 - AUX:** To listen to audio signals from external units.
7. Set volume level and **X-Bass**, and then press **POWER** button to standby mode.
8. When the timer that has been set is reached, the system will turn on automatically and "TIMER" indicator will blink on the display.



9. If you want to snooze for a few more minutes, you can press **SNOOZE** button. The system will go to standby mode ("SNOOZE" indicator appear on display) and then turn on again 5 minutes later.

You can repeat this function as many times as you desire within 119 minutes from the preset automatically **PLAY** time.

Note:

1. If you want to exit snooze mode, press **POWER** button to turn on the system.
2. Unless you cancel it, the "PRESET TIMER" function will be active everyday at the same preset time. To cancel the "PRESET TIMER" function, press and hold **TIMER** button for about 3 seconds until the "TIMER" indicator disappears from the display.

SLEEP SETTING

When the sleep timer is used, the power is automatically turned off after the specified time passes.

1. Press the **SLEEP/TIMER** button while the power is on. "SLEEP 90" lights in the display.
 
2. Press the **SLEEP/TIMER** button repeatedly to select the length of remaining time until the unit turns off.

It changes the indicator in the following way:

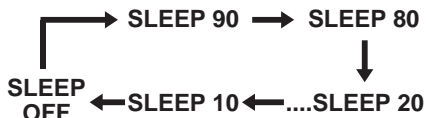
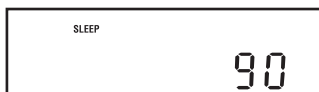

The sleep timer is set and the word "SLEEP" is shown on the display.

To cancel the sleep timer, press the **SLEEP/TIMER** button once and "SLEEP" will disappear from display.

Note: Press **SLEEP/TIMER** button to set the sleep timer after 5 seconds. The sleep setting is automatically turned on.

LISTENING TO THE RADIO

TUNING INTO A STATION MANUALLY

1. Press the **FUNCTION** button to TUNER.

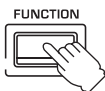

2. Press the **STOP/BAND** button to select the desired band.



3. Press the **TUNING/SKIP** buttons to select a station.

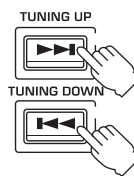

TO SEARCH FOR A STATION AUTOMATICALLY

Press the **TUNING/SKIP** button for 1 to 2 seconds, and a station is searched for automatically. After tuning in a station, the search stops.

The search may not stop at a station with a very weak signal.

TO RECEIVE THE FM BROADCAST IN STEREO

When receiving FM broadcasts in stereo, the word "STEREO" will illuminate.



PRESETTING STATION (for remote only)

Your favourite radio stations can be tuned in to by selecting their preset numbers. It is possible to store stations of any band in order of your choice.

Manual memory presetting

This feature allows you to manually preset stations to any desired channel.

1. Set to the desired band and station.

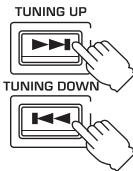

2. Press the **MEM** button until the MEMORY indicator blinks.



3. Press the **PRESET/REPEAT** button to select a channel number for the preset station on the remote control.



4. Press the **MEM** button again to memorize the station.



5. Repeat steps 1 to 4 for the next preset.

TUNING INTO A PRESET STATION

Press the **PRESET/REPEAT** button on the remote control to select a preset number.



NOTE:

If a button is not pressed within 10 seconds the preset mode will exit automatically.

CD PLAYBACK

1. Press the **FUNCTION** button to load CD.

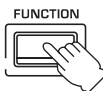

2. Press the **CD OPEN/CLOSE** button to open CD door. Place a disc in the CD tray with the label face front and then press the **CD OPEN/CLOSE** button to close CD door. The total number of tracks will show on the display.



3. To start playing, press the **▶|| PLAY/PAUSE** button.



TO INTERRUPT PLAYBACK

Press the **▶|| PLAY/PAUSE** button.

The track time will blink.

To resume playback, press the **▶|| PLAY/PAUSE** button again.

TO STOP PLAYBACK

Press the **■ STOP** button.

NOTE:

1. Do not push the CD door to close it.
2. CD door cannot open while power is off.

Locating a particular point in a track

To move backward at high speed

Keep the **SKIP ◀◀** button pressed during play and release at the desired point.

To move forward at high speed

Keep the **SKIP ▶▶** button pressed during play and release at the desired point.

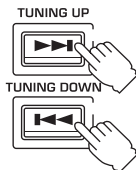

Press and hold

Searching for the beginning of a track

To find a previous track

Press the **SKIP ◀◀** button once to return to the beginning of the current track.

Press the **SKIP ◀◀** button repeatedly to skip tracks backward one by one.

To skip tracks

Press the **SKIP ▶▶** button repeatedly to skip track(s) forward one by one.

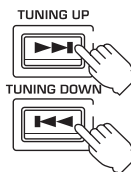

Press

PROGRAMMING TRACKS - in a CD stop mode

1. Press the  **MEM** button.

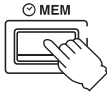

3. Press the  **MEM** button again.

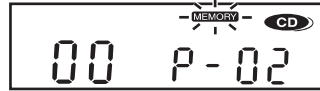
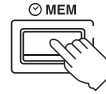

2. Press the  **SKIP**  buttons to select the desired tracks.

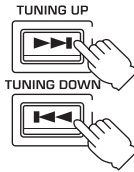

4. Repeat step 2 and 3 to program additional tracks, after you have finished program and memory indicator is blinking on display. Press  **PLAY/PAUSE** button to start playback of the programmed tracks and memory indicator will appear on display.



To check the program

While in the stop mode, press the  **MEM** button. The disc, track and program numbers will appear on the display.



Press the  **MEM** button again to view the other programmed selections.

These displays do not appear during programmed play.

To play the programmed tracks

Press the  **PLAY/PAUSE** button.

To stop programmed play

Press the **STOP** button, if you want to recover programmed play. You can first press  **MEM** button and then press  **PLAY** button.

To clear the memory content

Press the **STOP** button and then open the CD door or press  **MEM** button and then press the **STOP** button in stop mode.

REPEAT PLAY (for remote only)

This function will allow a single tracks or all the tracks on the disc to be played repeatedly.

TO REPEAT THE SAME TRACK

Press the **PRESET/REPEAT** button once during playback, the repeat one indicator will blink.

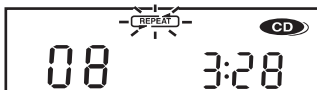

TO REPEAT THE WHOLE DISC

Press the **PRESET/REPEAT** button a second time to repeat all tracks, the repeat all indicator will light.

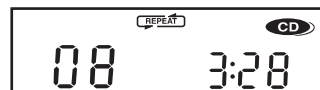

TO CANCEL REPEAT PLAY

Press the **PRESET/REPEAT** button until REPEAT indicator is switched off.

INTRODUCTION PLAY - at CD stop mode and CD play mode (for remote only)

This function allows the first 10 seconds of each track of the disc to be played.

RANDOM PLAY at CD play mode and CD stop mode (for remote only)

All the tracks on the disc can be played in random order.

Press the **INTRO** button.

INTRO appears in the display on the unit.



To cancel introduction play

Press the **STOP** or **INTRO** button so that "INTRO" in the display disappears.

1. INTRO play can be performed during program play.
2. INTRO play can be performed during random play.
3. RANDOM play can be performed during intro play.
4. RANDOM play can't be performed during program play.

Press the **RANDOM** button.

RANDOM appears in the display and the disc will play automatically.



To cancel random play

Press the **STOP** or **RANDOM** button so that "RANDOM" in the display disappears.

SATELLITE RADIO

NOTE:

The SKYFi Receiver **MUST** be activated by contacting XM RADIO. (1-800-852-9696 or www.xmradio.com) Follow the instructions included in the SKYFi Receiver carton to contact XM RADIO and activate the SKYFi Receiver.

Place the SKYFi Receiver firmly in the cradle. Change the function to SAT. Push the ON button on the SKYFi Receiver and the display on the SKYFi Receiver will light. The SKYFi is now ready to use. Use the SKYFi owner's manual for complete instructions on SKYFi operation and many features.

The SKFi Receiver will automatically turn off when any other function is selected.

Select the SAT function again and press the ON button on the SKYFi Receiver to return to receive XM Satellite Radio programming.

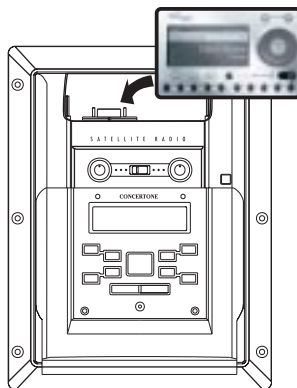

MAINTENANCE

CLEAN CD

If the CD skips or will not play, the disc may need cleaning. Before playing, wipe the disc from the centre out with a cleaning cloth. After playing, store the disc in its case.



CLEANING THE UNIT

Do not use volatile chemicals on the unit. Clean by lightly wiping with a soft cloth.

IMPORTANT NOTICE:

- If an abnormal display indication or an operating problem occurs, turn off power. Wait at least 5 seconds, then turn on power.
- Before transporting the unit, remove the disc from the CD tray.

SPECIFICATIONS

TUNER SECTION

Frequency range	FM 87.5 -108 MHz AM 520 - 1,710 kHz (USA and Canada)
Antenna	External 75ohm automotive type antenna

AMPLIFIER SECTION

Power output 10% T.H.D.	(A) 20W x 2 (Subwoofer) + 10W x 4 (B) 10W x 2
Power requirements	10/16 Volts DC

COMPACT DISC PLAYER SECTION

Frequency Response	40 - 20,000 Hz
Signal to noise ratio	60 dB
Dynamic Range	70 dB
Total harmonic Distortion	0.5% (Normal) T.H.D.
Separation	40 dB (at 1 kHz)

GENERAL (Tuner/CD Player)

Installation size:	Approx: 8-1/4" (W) x 6-1/2" (D) x 10-3/4" (H) (Inch)
Weight:	Approx: 5.28 Lbs.

Specifications and external appearance are subject to change without advance notice due to continuous product improvement.

SYSTEM CONNECTIONS

CONNECTION DIAGRAM

Make correct connections as illustrated in the connection diagram.

- A** From XM Satellite Radio Antenna
NOTE: Some XM antennas will have only one antenna cable. This is a factory design and will function normally.
- B** From Antenna
- C** From optional TV output jack

SPEAKER CONNECTIONS

Be sure to connect stripe to stripe (-) and plain to plain (+) when hooking up speaker wires. This is to prevent any 'phasing' problems.

Notes:

- Use speakers with an impedance of 4 to 8 ohms, and with adequate power handling capacities. Otherwise, speaker may be damaged.
- DO NOT connect speakers in parallel. DO NOT connect the terminals of speaker system to the vehicle chassis.

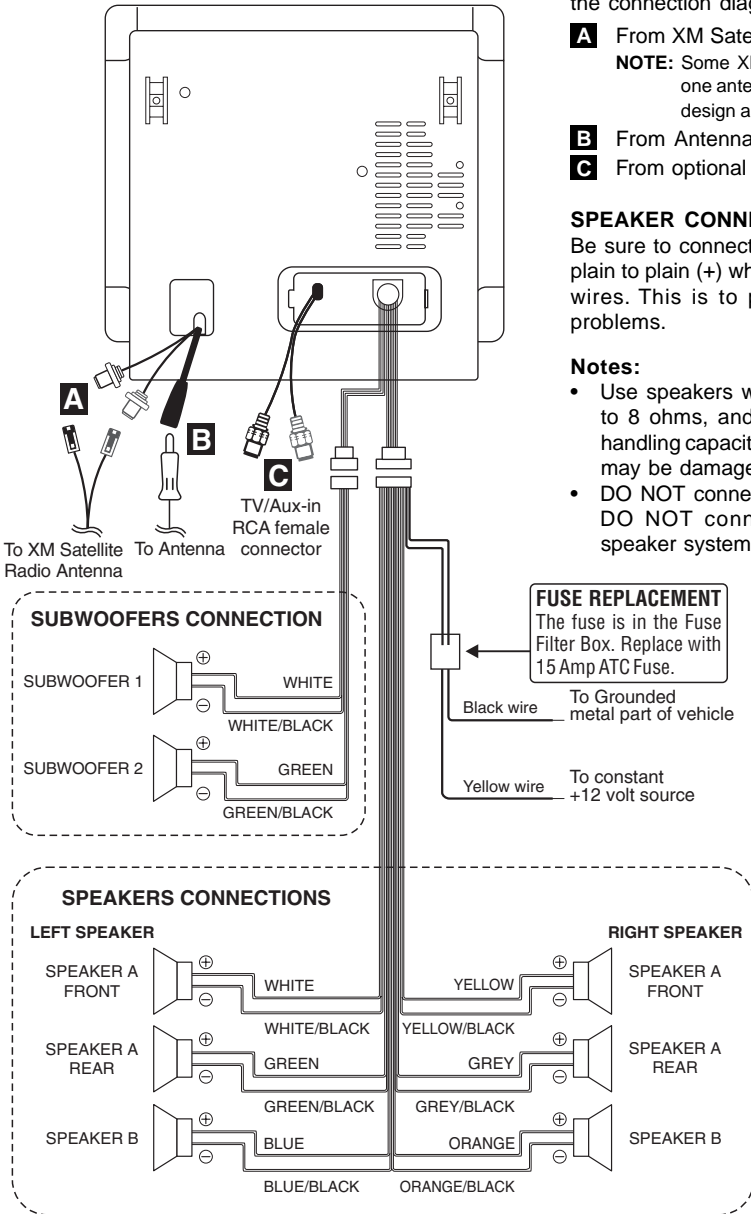

Caution:

Never use the \ominus cord of each speaker in common. When replacing the fuse, be sure to use 15 Amp ATC fuse. Use of a fuse of higher amperage may cause serious damage to the unit.